

## **BOEING and AIRBUS -- ALL MODELS**

### **3519-153 SINGLE POCKET DOOR ASSEMBLY with UPPER SUPPORT PANEL & SHEAR PINS - Mechanical**

#### FEATURES

- UPPER SUPPORT PANEL AND SHEAR PINS ALLOW DOOR TO BREAK BELOW HEADLINER
- UNIQUE FRANGIBLE HINGES ALLOW DOOR TO ROTATE FOR DECOMPRESSION/EGRESS WITH DOOR RESET CAPABILITY
- THIS DOOR DESIGN ELIMINATES THE NEED FOR A ROTATING HEADER/DOOR JAMB (TOP)
- DOOR AND SUPPORT PANELS ASSEMBLED & ATTACHED FOR QUICK, EASY INSTALLATION
- MECHANICAL OPERATION

#### DOOR TYPE

SINGLE WITH UPPER PANEL AND SHEAR PINS

#### RECOMMENDED LOCATION(S)

THROUGHOUT CABIN

#### DOOR OPENING SIZE

24" TO 42" (MAXIMUM)

#### POCKET SIZE REQUIRED

2.25" OR MORE

#### WEIGHT (WITHOUT COVERING)\*

34.0 LBS.

\* INCLUDES DOOR/SUPPORT PANELS NOT COVERING MATERIAL

#### PART NUMBERS

3519-153-1

3519-153-2 (OPPOSITE)

**NOTE: DECORATIVE PARTITION  
MUST BE EASILY REMOVABLE FOR  
DOOR INSTALLATION AND ADJUSTMENT.**

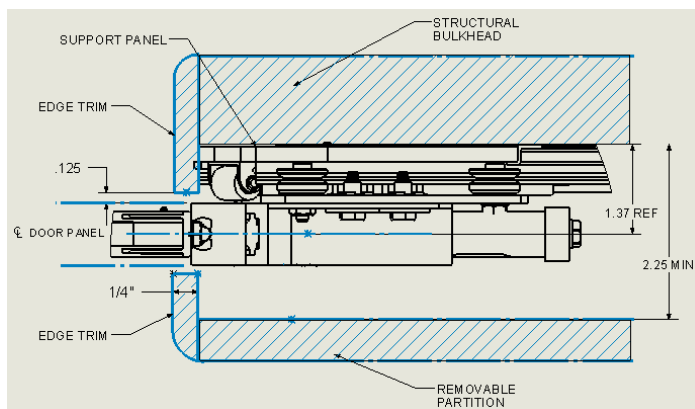

3519-153-1 MECHANICAL DOOR PLAN VIEW